

BUTLER

Assembly Instructions
Style Number 3009

SPECIALTY COMPANY
8200 SOUTH CHICAGO AVE., CHICAGO, IL 60617

PACKAGED

- | | |
|-------------------------------|------------------------------------|
| (A) 1 – Top | (G) 16 – Flat Washer Dia:1/4"*16mm |
| (B) 4 – Leg | (H) 8 – Bolt Dia: 1/4"*1/2" |
| (C) 1 – Shelf with Bun feet | (I) 4 – "L" Bracket |
| (D) 1 – Allen Wrench Dia.1/4" | |
| (E) 8 – Bolt Dia:1/4"*2" | |
| (F) 16 – Lock Washer Dia:1/4" | |

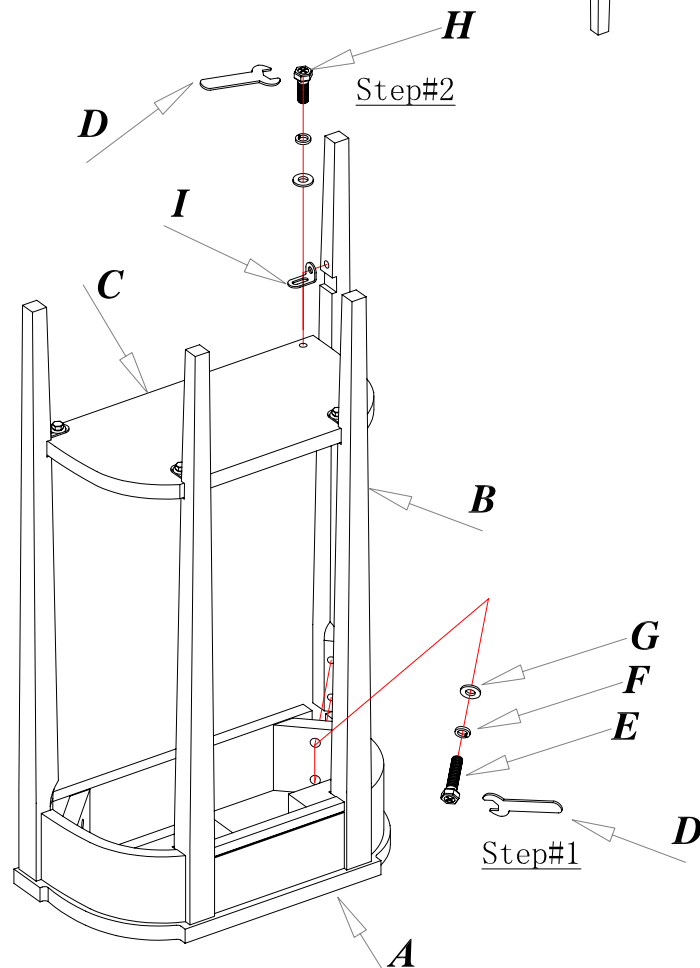
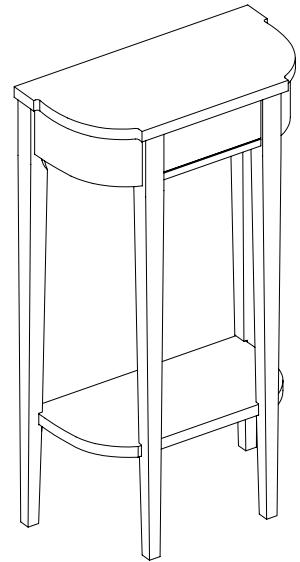

(*) Caution: DO NOT OVERTIGHTEN.

In any correspondence regarding this product, please include the complete Butler identification number located on the underside of the product.

We hope this Table will be a useful and decorative addition to your home for years to come.

Copyright © Butler Specialty Company, 04/2010